

High Power EDFA

Introduction

Optoplex designed and produced high power single-mode and polarization-maintaining EDFA, which met MSA compatible requirements. C-band MSA EDFA Module with +23 dBm Output Power is Optoplex standard product. Optoplex designed Pre-EDFA provides more than 35dB gain with -40dBm input power. The Double-Cladding pumped EDFA produces 2W output power.

Following shows the popular MSA EDFA configuration.

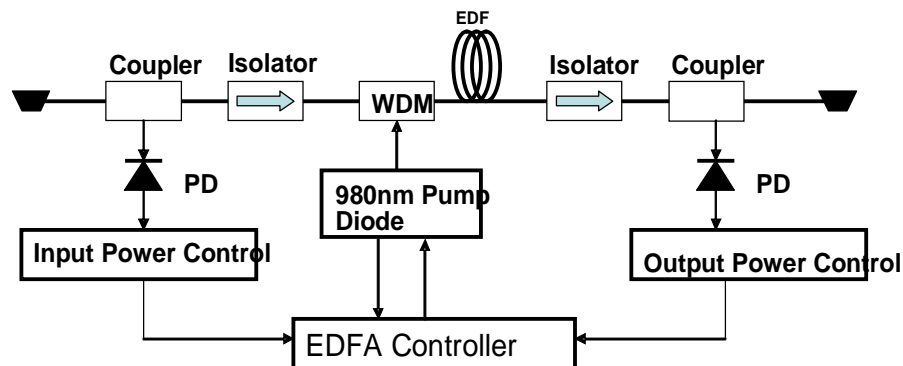

Key Features and Benefits

- 1530-1565nm wavelength range
- 23dBm output power
- MSA compatible Compact size
- 5Vdc power supply
- U-ART and USB communication interface
- Low Noise Figure

Applications

- Remote Sensing Amplifier
- Telecommunication
- Optical add/drop module
- Power equalization
- Lidar booster and pre-amplifier

23dBm Booster Specification

No	Parameter	Unit	Conditions	Specification			Note
				Min	Typ.	Max	
3.11	Wavelength Range	<i>nm</i>	C-Band	1530		1565	
3.12	Input Optical Power	<i>dBm</i>		-10	1	10	
3.13	Total Output Power	<i>dBm</i>			23		Pin>0dBm
3.14	Noise Figure	<i>dB</i>			5.5	6.0	Pout= -10 to 0dBm
		<i>dB</i>			6.5	7.0	Pin=10dBm
3.15	Polarization Mode Dispersion(PMD)	<i>ps</i>				0.5	
3.16	Polarization Dependent Gain (PDG)	<i>dB</i>				0.5	
3.17	Return Loss	<i>dB</i>	Pump Laser off	35			

Electrical Requirements

No	Parameter	Unit	Specification			Note
			Min	Typ.	Max	
3.21	Power Supply Voltage	<i>V</i>		5.0±0.15		
3.22	Power Consumption	<i>W</i>		3	6	
3.23	Cold Start Settle Time	<i>s</i>			10	
3.24	Warm Start Settle Time	<i>s</i>			0.1	
3.25	Transient Settle Time	<i>μs</i>		150	250	

Firmware Function

Parameter	Specification
Firmware Function	Field Upgradable
	Automatic Gain Control (AGC) Mode
	Automatic Output Power Control (AOPC) Mode
	Automatic Pump Power Control (APC) Mode
	Automatic Current Control (ACC) Mode
	Reset
	Disable
	Mute
Monitor	Total Input Power
	Total Output Power
	Pump Status
	Module Temperature
Alarms	Loss of Signal Alarm
	Loss of Output Power Alarm
	Module Temperature Alarm
	Pump Temperature Alarm
	Pump Bias Current Alarm

Mechanical specification

No	Parameter	Unit	Specifications	Notes
4.01	Outline		See Figure below	
4.02	Dimensions (L x W x H)	<i>mm</i>	90 x 70 x 15	
4.03	Connector Type	-	FC/APC (Standard)	
4.04	Fiber Type	-	SMF-28	
4.05	Pigtail Type	-	900um Tight Buffer	
4.06	Fiber Length	<i>m</i>	1.0 ± 0.1 (Standard)	
4.07	Fiber Bending Diameter	<i>mm</i>	> 50	

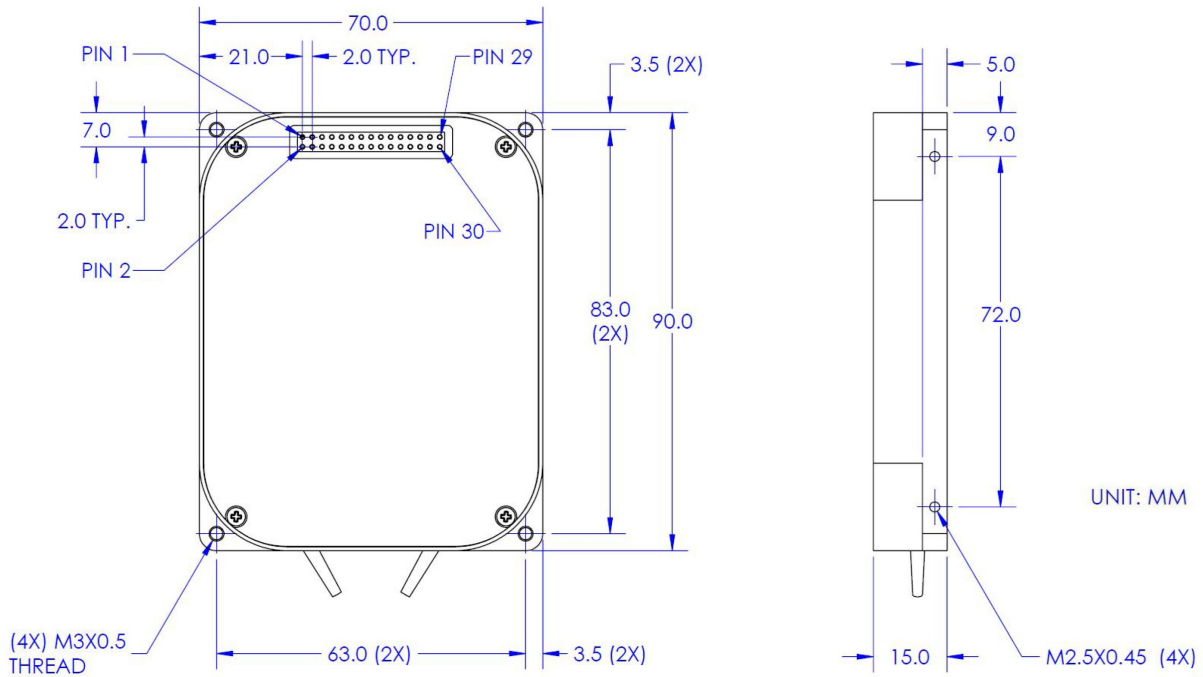

Pin Assignment

	Function		Function
1	5.0V	2	5.0V
3	NC	4	NC
5	GND	6	GND
7	Serial Input (LVTTTL, Idle high)	8	Serial Output (LVTTTL, Idle high)
9	GND	10	GND
11	NC	12	Reset Input (active low)
13	Amplifier Disable Input,(active high)	14	Output Power Mute Input (active high)
15	Case Temperature Alarm,(active high)	16	Common Alarm (active low)
17	Pump Temperature Alarm(active high)	18	Pump Bias Alarm (active high)
19	Loss of input alarm (active high)	20	Loss of Output alarm (active high)
21	Input Power Monitor Ground	22	Output Power Monitor Ground
23	Input Power Monitor	24	Output Power Monitor
25	GND	26	GND
27	NC	28	NC
29	5.0V	30	5.0V

ORDERING INFORMATION

